

Approval body for construction products
and types of construction

Bautechnisches Prüfamt

An institution established by the Federal and
Laender Governments



European Technical Assessment

ETA-06/0108
of 17 October 2018

English translation prepared by DIBt - Original version in German language

General Part

Technical Assessment Body issuing the
European Technical Assessment:

Deutsches Institut für Bautechnik

Trade name of the construction product

Liebig® Safety Bolt™

Product family
to which the construction product belongs

Mechanical fasteners for use in concrete

Manufacturer

EJOT Baubefestigungen GmbH
In der Stockwiese 35
57334 Bad Laasphe
DEUTSCHLAND

Manufacturing plant

EJOT Plant 14

This European Technical Assessment
contains

12 pages including 3 annexes which form an integral part
of this assessment

This European Technical Assessment is
issued in accordance with Regulation (EU)
No 305/2011, on the basis of

EAD 330232-00-0601

The European Technical Assessment is issued by the Technical Assessment Body in its official language. Translations of this European Technical Assessment in other languages shall fully correspond to the original issued document and shall be identified as such.

Communication of this European Technical Assessment, including transmission by electronic means, shall be in full. However, partial reproduction may only be made with the written consent of the issuing Technical Assessment Body. Any partial reproduction shall be identified as such.

This European Technical Assessment may be withdrawn by the issuing Technical Assessment Body, in particular pursuant to information by the Commission in accordance with Article 25(3) of Regulation (EU) No 305/2011.

Specific Part

1 Technical description of the product

The Liebig® Safety Bolt™ of sizes M6, M8, M10, M12 and M16 is an anchor made of galvanised steel which is placed in an drilled hole and anchored by torque-controlled expansion. Product and product description is given in Annex A.

2 Specification of the intended use in accordance with the applicable European Assessment Document

The performances given in Section 3 are only valid if the anchor is used in compliance with the specifications and conditions given in Annex B.

The verifications and assessment methods on which this European Technical Assessment is based lead to the assumption of a working life of the anchor of at least 50 years. The indications given on the working life cannot be interpreted as a guarantee given by the producer, but are to be regarded only as a means for choosing the right products in relation to the expected economically reasonable working life of the works.

3 Performance of the product and references to the methods used for its assessment

3.1 Mechanical resistance and stability (BWR 1)

Essential characteristic	Performance
Characteristic resistance to tension load (static and quasi-static loading)	See Annex C 1
Characteristic resistance to shear load (static and quasi-static loading)	See Annex C 2
Displacements (static and quasi-static loading)	See Annex C 1 und C 2
Characteristic resistance and displacements for seismic performance categories C1 and C2	No performance assessed

3.2 Safety in case of fire (BWR 2)

Essential characteristic	Performance
Reaction to fire	Class A1
Resistance to fire	See Annex C 3

4 Assessment and verification of constancy of performance (AVCP) system applied, with reference to its legal base

In accordance with the European Assessment Document EAD No. 330232-00-0601 the applicable European legal act is: [96/582/EC].

The system to be applied is: 1

5 Technical details necessary for the implementation of the AVCP system, as provided for in the applicable EAD

Technical details necessary for the implementation of the AVCP system are laid down in the control plan deposited with Deutsches Institut für Bautechnik.

Issued in Berlin on 17 October 2018 by Deutsches Institut für Bautechnik

Dr.-Ing. Lars Eckfeldt
p. p. Head of Department

beglaubigt:
Tempel

Liebig Safety Bolt™

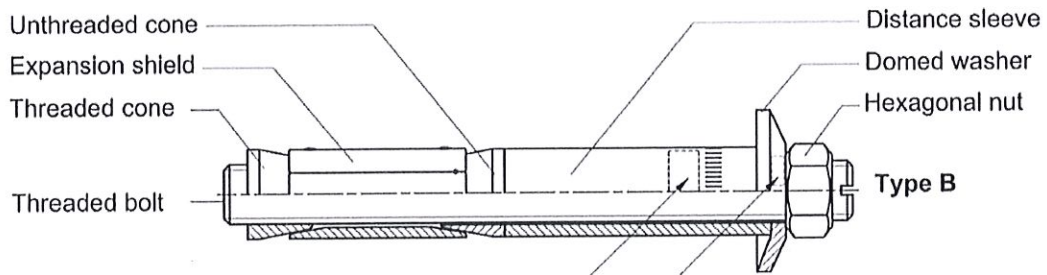

Marking:

Identifying mark: \otimes
 Thread size: M ..
 Max. fixture thickness: t_{fix}
 Setting depth marking: knurl or groove

For example: \otimes M10/40

Marking:

Trade name: S (Safety Bolt)

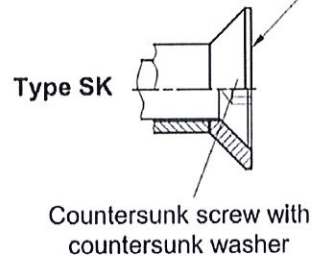
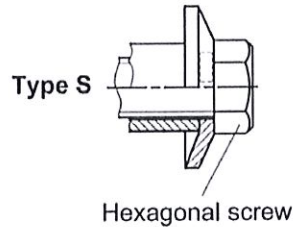

Liebig Safety Bolt™ after installation

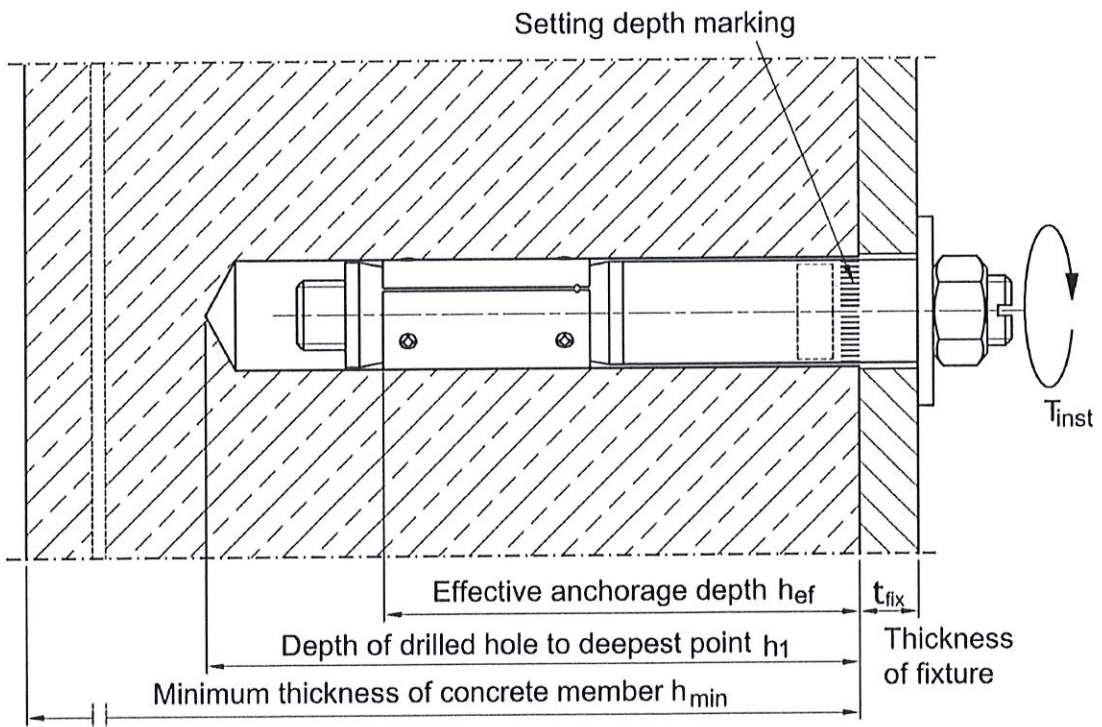

Liebig® Safety Bolt™

Annex A1

Product description
Product and installation situation

Liebig Safety Bolt™

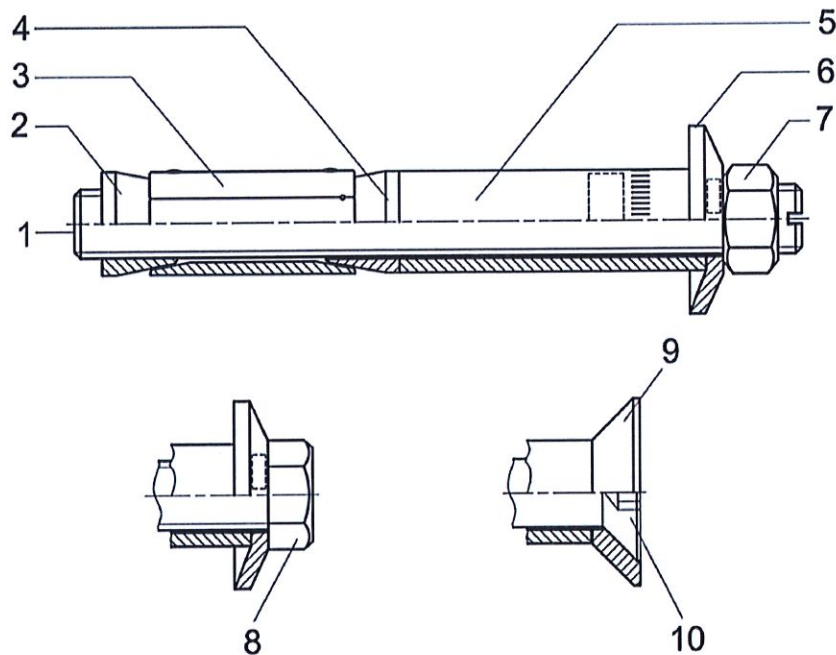

Table 1: Materials

Part	Designation	Material ^{1) 2)}
1	Threaded bolt	EN ISO 898-1: grade 8.8
2	Threaded cone	EN10263: 1.0214 / EN 10087: 1.0718
3	Expansion shield	EN 10025: 1.0037 / EN 10139: 1.0330
4	Unthreaded cone	EN10263: 1.0214 / EN 10087: 1.0718
5	Distance sleeve	EN 10025: 1.0037 / EN 10139: 1.0330
6	Domed washer	EN 10139: 1.0330
7	Hexagonal nut	EN 20898-2: grade 8
8	Hexagonal screw	EN ISO 898-1: grade 8.8
9	Countersunk washer	EN 10025: 1.0037 / EN 10087: 1.0718
10	Countersunk screw	EN ISO 898-1: grade 8.8

¹⁾ Parts 1 - 10 zinc electroplated according to EN ISO 4042 $\geq 5 \mu\text{m}$, passivated.

²⁾ Parts 2, 6, 7 and 9 with lubrication.

Liebig® Safety Bolt™

Annex A2

Product description
Materials

Liebig Safety Bolt™

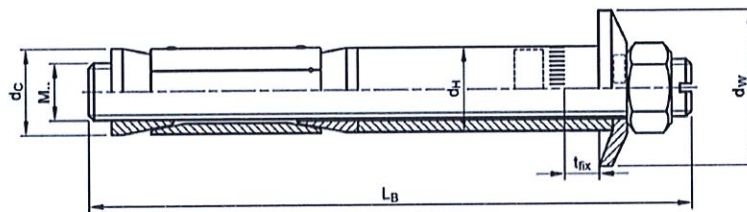

Type B

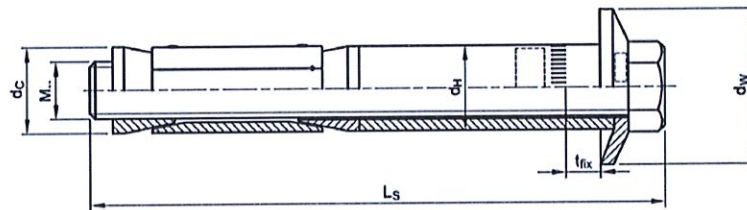

Type S

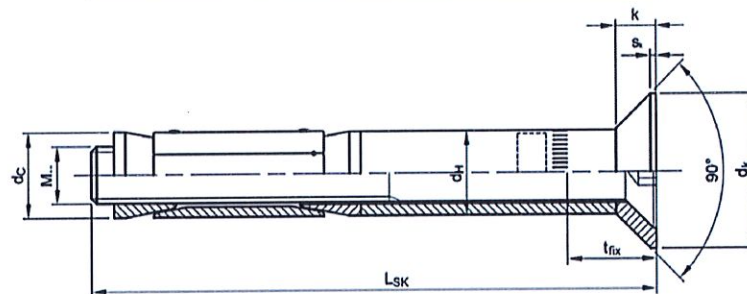

Type SK

Table 2: Dimensions of the anchors

Anchor size			M6-10/45/..	M8-12/55/..	M10-15/70/..	M12-20/80/..	M16-25/100/..
Type B	$t_{fix}^{1)}$	[mm]	0 - 200	0 - 200	0 - 200	0 - 200	0 - 200
	L_B	[mm]	65 - 265	80 - 280	95 - 295	115 - 315	145 - 345
Type S	$t_{fix}^{1)}$	[mm]	1 - 200	1 - 200	2 - 200	5 - 200	5 - 200
	L_S	[mm]	65 - 265	76 - 275	93 - 291	113 - 308	145 - 340
Type SK	$t_{fix}^{1)}$	[mm]	6 - 200	8 - 200	8 - 200	10 - 200	15 - 200
	L_{SK}	[mm]	60 - 250	75 - 265	90 - 280	105 - 295	135 - 320
	s_k	[mm]	0,5	0,5	1	1	1
	k	[mm]	5,5	6,5	7	8	14
	d_k	[mm]	20	24	27	33	50
d_c	[mm]	10	12	15	19,7	24,7	
d_H	[mm]	9,5	11,7	14,7	19	24	
d_w	[mm]	15	20	25	30	40	

¹⁾ t_{fix} = Thickness of fixture

Liebig® Safety Bolt™

Product description
Dimensions of the anchor

Annex A3

English translation prepared by DIBt

Specifications of intended use

Anchorage subject to:

- Static and quasi-static loads
- Fire exposure

Base materials:

- Cracked and uncracked concrete
- Reinforced or unreinforced normal weight concrete without fibres, strength class C20/25 to C50/60 according to EN 206:2013

Use conditions (Environmental conditions):

- Structures subject to dry internal conditions

Design:

- Anchorages are designed under the responsibility of an engineer experienced in anchorages and concrete work,
- Verifiable calculation notes and drawings are prepared taking account of the loads to be anchored. The position of the anchor is indicated on the design drawings (e. g. position of the anchor relative to reinforcement or to supports, etc.),
- Anchorages are designed in accordance with FprEN 1992-4:2017 and EOTA Technical Report TR 055, design method A.

Installation:

- Anchor installation carried out by appropriately qualified personnel and under the supervision of the person responsible for technical matters of the site.
- Anchor installation in accordance with the manufacturer's specifications and drawings and using the appropriate tools.
- Hole drilling by hammer drill only.
- Cleaning of the hole of drilling dust.
- Application of specified torque moment using a calibrated torque tool.
- In case of aborted hole: new drilling at a minimum distance away of twice the depth of the aborted hole, or smaller distance if the aborted drill hole is filled with high strength mortar and if under shear or oblique tension loads it is not in the direction of load application.

Liebig® Safety Bolt™

Intended use
Specifications

Annex B1

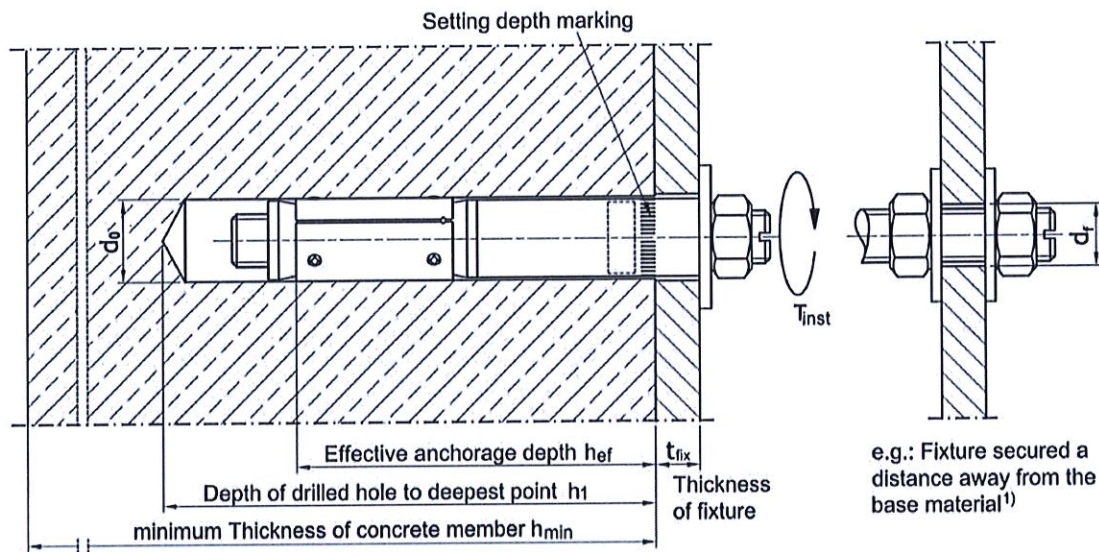

Table 3: Installation data

Liebig® Safety Bolt™			Anchor size				
			M6 10/45/..	M8 12/55/..	M10 15/70/..	M12 20/80/..	M16 25/100/..
Nominal diameter of drill bit	d_o	[mm]	10	12	15	20	25
Cutting diameter of drill bit	$d_{cut} \leq$	[mm]	10,45	12,5	15,5	20,55	25,55
Depth of drilled hole to deepest point	$h_1 \geq$	[mm]	60	70	85	100	125
Diameter of clearance hole in the fixture	$d_f \leq$	[mm]	12	14	17	21	26
	$d_f^{(1)} \leq$	[mm]	7	9	12	14	18
Maximum thickness of fixture	$t_{fix} \leq$	[mm]	200	200	200	200	200
Width across flats type B + S	SW	[mm]	10	13	17	19	24
Width across flats type SK	S	[mm]	4	5	6	8	10
Torque moment type B	T_{inst}	[Nm]	8	15	40	70	115
Torque moment type S			8	20	60	90	170
Torque moment type SK			12	20	60	90	190

¹⁾ Mounting on the threaded bolt (only type B)

Table 4: Minimum thickness of concrete member, spacing and edge distance

Liebig® Safety Bolt™			Anchor size				
			M6 10/45/..	M8 12/55/..	M10 15/70/..	M12 20/80/..	M16 25/100/..
Minimum thickness of concrete member	h_{min}	[mm]	100	110	140	160	200
Minimum spacing	s_{min}	[mm]	60	100	150	200	250
	for $c \geq$	[mm]	130	200	300	500	600
Minimum edge distance	c_{min}	[mm]	80	100	150	200	250
	for $s \geq$	[mm]	140	200	250	380	440

Intervals may be interpolated linearly.

Liebig® Safety Bolt™

Annex B2

Intended use
Installation data,
Minimum thickness of concrete member, spacing and edge distance

Table 5: Design method A
Characteristic values for tension loads

Liebig® Safety Bolt™			Anchor size				
			M6 10/45/..	M8 12/55/..	M10 15/70/..	M12 20/80/..	M16 25/100/..
Steel failure							
Characteristic resistance	$N_{Rk,s}$	[kN]	16,1	29,3	46,4	67,4	125,3
Partial safety factor	γ_{Ms}	[-]	1,5				
Pull-out failure							
Characteristic resistance in cracked concrete C20/25	$N_{Rk,p}$	[kN]	6	9	16	– ¹⁾	– ¹⁾
Characteristic resistance in uncracked concrete C20/25	$N_{Rk,p}$	[kN]	7,5	12	20	– ¹⁾	– ¹⁾
Increasing factors for $N_{Rk,p}$	Ψ_C	C25/30	1,12				
		C30/37	1,22				
		C35/45	1,32				
		C40/50	1,41				
		C45/55	1,50				
		C50/60	1,58				
Installation safety factor	γ_{Inst}	[-]	1,2	1,2	1,0	1,0	1,0
Concrete cone failure							
Effective anchorage depth	h_{ef}	[mm]	45	55	70	80	100
Factor k_1	$k_{cr,N}$		7,7				
	$k_{ucr,N}$		11,0				
Spacing	$s_{cr,N}$	[mm]	3 x h_{ef}				
Edge distance	$c_{cr,N}$	[mm]	1,5 x h_{ef}				
Installation safety factor	γ_{Inst}	[-]	1,2	1,2	1,0	1,0	1,0
Concrete splitting failure							
Spacing (splitting)	$s_{cr,sp}$	[mm]	5 x h_{ef}				
Edge distance (splitting)	$c_{cr,sp}$	[mm]	2,5 x h_{ef}				
Installation safety factor	γ_{Inst}	[-]	1,2	1,2	1,0	1,0	1,0

¹⁾ Pull-out failure not decisive.

Table 6: Displacements under tension loads

Liebig® Safety Bolt™			Anchor size				
			M6 10/45/..	M8 12/55/..	M10 15/70/..	M12 20/80/..	M16 25/100/..
Cracked concrete C20/25	N	[kN]	2,4	3,6	7,6	12,3	17,2
	d_{N0}	[mm]	0,2	0,4	0,4	0,6	0,6
	$d_{N\infty}$	[mm]	0,8	0,8	0,8	0,8	0,8
Uncracked concrete C20/25	N	[kN]	3,0	4,8	9,5	17,2	24,0
	d_{N0}	[mm]	0,2	0,3	0,3	0,4	0,4
	$d_{N\infty}$	[mm]	0,8	0,8	0,8	0,8	0,8

Liebig® Safety Bolt™

Annex C1

Performances
Design method A: Characteristic values for tension loads,
Displacements under tension loads

Table 7: Design method A
Characteristic values for shear loads

Liebig® Safety Bolt™			Anchor size				
			M6 10/45/..	M8 12/55/..	M10 15/70/..	M12 20/80/..	M16 25/100/..
Steel failure for shear load without lever arm							
Characteristic resistance	$V_{RK,s}$ [kN]		15	25	39	60	96
Partial safety factor	γ_{Ms} [-]		1,25				
Steel failure for shear load with lever arm							
Characteristic bending moment	$M^0_{RK,s}$ [Nm]		12	30	60	105	266
Partial safety factor	γ_{Ms} [-]		1,25				
Concrete pry-out failure							
Factor	k_g [-]		1		2		
Installation safety factor	γ_{Inst} [-]		1,0				
Concrete edge failure							
Effective length of anchor under shear load	ℓ_f [mm]		45	55	70	80	100
Outside diameter of anchor	d_{nom} [mm]		10	12	15	20	25
Installation safety factor	γ_{Inst} [-]		1,0				

Table 8: Displacements under shear loads

Liebig® Safety Bolt™			Anchor size				
			M6 10/45/..	M8 12/55/..	M10 15/70/..	M12 20/80/..	M16 25/100/..
Cracked and uncracked concrete C20/25 - C50/60	V [kN]		8,6	14,3	22,3	34,3	54,9
	d_{v0} [mm]		2,5	2,9	3,2	4,1	5,0
	$d_{v\infty}$ [mm]		3,8	4,4	4,5	6,2	7,5

Liebig® Safety Bolt™

Performances
Design method A: Characteristic values for shear loads,
Displacements under shear loads

Annex C2

Table 9: Design method A

**Characteristic resistances in cracked and uncracked concrete
C20/25 to C50/60 under fire exposure**

Liebig® Safety Bolt™				Anchor size				
				M6 10/45/..	M8 12/55/..	M10 15/70/..	M12 20/80/..	M16 25/100/..
Tension resistance <small>Fire resistance class</small>								
Characteristic resistance	R30	$N_{Rk,s,fi}$	[kN]	0,2	0,4	0,9	1,7	3,1
	R60	$N_{Rk,s,fi}$	[kN]	0,2	0,3	0,8	1,3	2,4
	R90	$N_{Rk,s,fi}$	[kN]	0,1	0,3	0,6	1,1	2,0
	R120	$N_{Rk,s,fi}$	[kN]	0,1	0,2	0,5	0,8	1,6
Spacing		$s_{cr,fi}$	[mm]	4 x h_{ef}				
Edge distance		$c_{cr,fi}$	[mm]	2 x h_{ef}				
		c_{min}	[mm]	In fire attack from more than one side: ≥ 300 mm				

Shear resistance without lever arm <small>Fire resistance class</small>								
Characteristic resistance	R30	$V_{Rk,s,fi}$	[kN]	0,2	0,4	0,9	1,7	3,1
	R60	$V_{Rk,s,fi}$	[kN]	0,2	0,3	0,8	1,3	2,4
	R90	$V_{Rk,s,fi}$	[kN]	0,1	0,3	0,6	1,1	2,0
	R120	$V_{Rk,s,fi}$	[kN]	0,1	0,2	0,5	0,8	1,6
Shear resistance with lever arm								
Characteristic resistance	R30	$M^0_{Rk,s,fi}$	[Nm]	0,2	0,4	1,1	2,6	6,6
	R60	$M^0_{Rk,s,fi}$	[Nm]	0,1	0,3	1,0	2,0	5,0
	R90	$M^0_{Rk,s,fi}$	[Nm]	0,1	0,3	0,7	1,7	4,3
	R120	$M^0_{Rk,s,fi}$	[Nm]	0,1	0,2	0,6	1,3	3,3

Liebig® Safety Bolt™		Annex C3
Performances Design method A: Characteristic values of resistances under fire exposure		